

INDUSTRIAL RELATIONS
SECTION

NOV 9 1927

THE FRISCO EMPLOYEES' MAGAZINE



**NOVEMBER
1927**

**VOL. V
NO. II**

Jerkless Travel —Wearless Journals

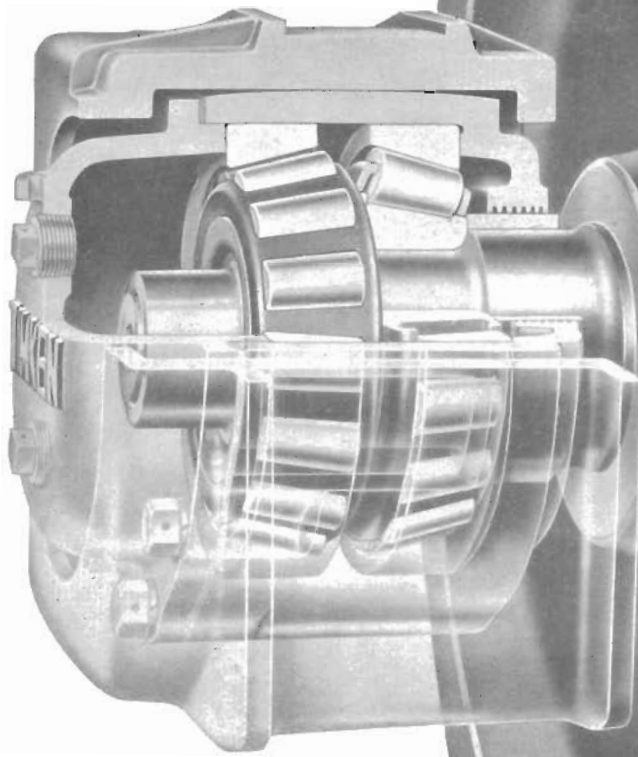

THE most sure and comfortable travel ever known is made possible by Timken Bearings in railroad car journals. Utterly jerkless starting, riding, sleeping and dining are realities on the famous trains equipped with Timken Tapered Roller Bearings. Hot-box hazards and delays are unknown.

Even more is gained than good will, reputation and traffic volume. 88% of starting power is saved; tonnage rating is unaffected at low temperatures. Journal wear is virtually non-existent. A fraction of previous maintenance cost permits improved operation in every phase. Only the Timken combination of friction-elimination and utmost endurance does it all! THE TIMKEN ROLLER BEARING COMPANY, CANTON, OHIO

X-Ray view of a Timken-equipped Railroad Journal. Timken tapered construction, Timken *POSITIVELY ALIGNED ROLLS*, and Timken-made electric steel assure *complete* protection against all the thrust, shock, speed and weight which are set up by the motion of flanged steel wheels against steel rails and curves

TIMKEN *Tapered Roller* **BEARINGS**

Live in Beautiful

ROSEMONT

Near Pensacola, Florida

ROSEMONT GOLDEN ACRE FARMS are located in the highlands of Escambia County, along the Frisco Lines, only 12 miles from Pensacola and the new Frisco Gulf Port.

This land is 150 feet above sea level, all high and dry, and with good drainage and live streams. Rosemont offers you an opportunity to secure a self-supporting homesite. Twenty acres of this fertile soil, properly tilled, will make you independent. An all-year-around climate gives this section the advantage of producing from two to six diversified crops a year.

Pensacola, Fla., is a thriving city of more than 40,000 population, where you will find every modern convenience, such as churches, schools, theatres, stores and practically everything you could wish for.

Prices in Rosemont are exceptionally low now. The opportunities are unlimited. We suggest that you act right now while the opportunity is still open.

Low rate excursion to inspect property every week—inquire.

*Return the
Coupon Today!*

Clip the coupon below and return it. We'll gladly send you descriptive literature and any other information you may desire.

McCASKILL ESTATES

703 Frisco Building
SAINT LOUIS, MO.

CHICAGO OFFICE: 1228 Union Trust Bldg., 7 S. Dearborn St.

McCASKILL ESTATES, 703 Frisco Bldg., St. Louis, Mo.
 Gentlemen: Please send me descriptive literature and full
 information regarding the Rosemont Golden Acre Farms.
 Name _____
 Street _____
 City _____
 State _____

R. F. CARR, Memphis
President

W. E. LOWRY, Hickory Flat, Miss.
Vice-Pres. and General Manager



SPECIALIZING IN
RAILROAD BUILDING MATERIAL

Strong as Ever for the "Frisco"

GENERAL OFFICES
P. O. Box 1032

MEMPHIS, TENN.

Phone, Main 2312

In Fighting Fire—



SOLVAY
CALCIUM CHLORIDE
is 4 times as effective as plain water

Write for Booklet No. 8255
THE SOLVAY SALES CORPORATION
40 Rector St. New York

DE BARDELEBEN COALS

Sipsey — Empire — Corona — Carbon Hill — Hull

FOR

DOMESTIC, STEAM, GAS, BY-PRODUCT AND CERAMICS

DE BARDELEBEN COAL CORPORATION

The South's Largest Producers and Marketers of

HIGH GRADE COALS

*DeBardeleben Preparation
Gives Added Value*

Southern Railway Building
BIRMINGHAM, ALABAMA

WESTERN TIE AND TIMBER COMPANY

905 SYNDICATE TRUST BLDG.

WALTER POLEMAN, President
E. A. NIXON, Vice-President

A. R. FATHMAN, Vice-President
THOS. T. POLEMAN, Sec'y and Treas.

Treated and Untreated Cross and Switch Ties, Piling, Car and Track Oak

Owners of

KETTLE RIVER TREATING COMPANY

MADISON, ILLINOIS

Zinc and Creosoted CROSS TIES, Modern Adzing and Boring Machines

Treating Plants located at Madison and Edwardsville, Ill.

E. A. NIXON, President
A. R. FATHMAN, Vice-President
R. E. KNEELAND, V.-P. and G. Mgr.

E. J. STOCKING, Sales Mgr.
H. G. McELHINNEY, Sec'y and Gen. Supt.
J. E. PETERSON, Treasurer

Plants at —

SUPPLYING
PILING
for
J. W. McMURRY
on
BRIDGE WORK

ABERDEEN, MISS., *on Frisco*
COLUMBUS, MISS., *on Southern*
STEEN, MISS., *on Southern*
WIBLEY, MISS., *on C. & G.*
MILPORT, ALA., *on Southern*
FERNBANK, ALA., *on Southern*

MIKE P. PARRA

DEALER IN

TELEPHONE AND TELEGRAPH POLES

TIES AND PILING *for* RAILROAD CONSTRUCTION
AND FOUNDATIONS

BOX 30

COLUMBUS, MISS.